

Ersatzteilliste

Spare parts list

Liste de pièces détachées



Gläserspülautomat

Glasswashing machine

Lave-verres automatique

EcoStar 545 D

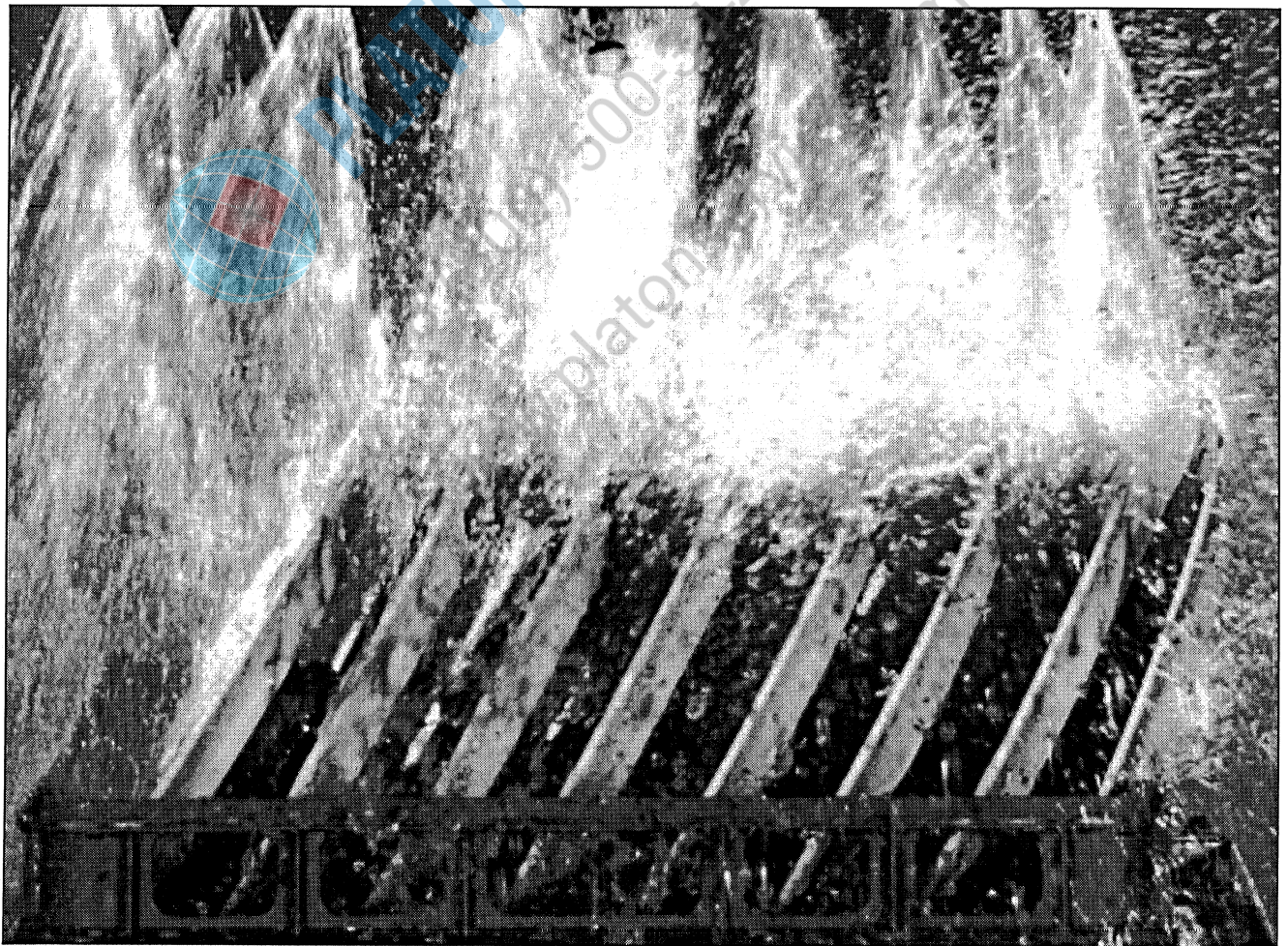

EcoStar 545 D

Inhaltsverzeichnis:	Contents:	Contenu:	Seite/ Page
01.02 Waschpumpe	Wash pump	Pompe de lavage	4
02.05 Pumpenansaugung	Pump suctioning	Aspiration de pompe	5
03.25 Wasch- und Nachspülsystem	Washing and rinsing system	Système de lavage et rinçage	6
04.08 Magnetventil	Solenoid valve	Electrovanne	8
05.01 Rücksaugeverhinderer	Reflux preventor	Dispositif anti-retour	9
06.08 Niveauregelung	Level control	Régulation de niveau	10
08.25 Einbauboiler	Incorporated boiler	Surchauffeur incorporé	11
09.05 Tankheizung	Tank heating	Chauffage de bac	13
10.07 Klarspülerdosierung	Rinse aid dosing unit	Doseur de produit tensio-actif	14
11.41 Elektroniksteuerung	Electronic control	Commande électronique	16
12.10 Elektroteile	Electrical parts	Pièces électriques	17
13.13 Baugruppen/Einzelteile	Component blocks/Parts	Blocs/Pièces détachées	19
14.08 Haubengestänge	Hood rod	Barre de capot	20
16.01 Einbauwasserenthärter	Incorporated softener	Adoucisseur incorpore	22
17.05 Reinigerdosierung	Detergent dosing unit	Doseur de detergent	24

KENNZEICHNUNG DER ERSATZTEILE

* / V DIESE TEILE EMPFEHLEN WIR
AUF LAGER ZU LEGEN!

V VERSCHLEISSTEIL!

ÄNDERUNGEN IN AUSFÜHRUNG
UND KONSTRUKTION
VORBEHALTEN.

SPECIAL MARKS OF SPARES

WE RECOMMEND TO STORE THESE
PARTS!

WEAR AND TARE PART!

WE RESERVE THE RIGHT TO CHANGE
EXECUTION AND CONSTRUCTION.

MARQUAGE SPECIALES DES PIECES

NOUS RECOMMANDONS DE PRENDRE
CES PIECES EN STOCK!

PIÈCE D'USURE!

NOUS NOUS RESERVONS LE DROIT DE
CHANGER L'EXECUTION ET LA
CONSTRUCTION.

MEIKO Maschinenbau GmbH & Co.

Englerstraße 3

D-77652 Offenburg

Telefon: 0781 / 203 - 0

Telefax: 0781 / 203 - 1179

www.meiko.de

e-mail: info@meiko.de

01.02 WASCHPUMPE

01.02 WASH PUMP

01.02 POMPE DE LAVAGE

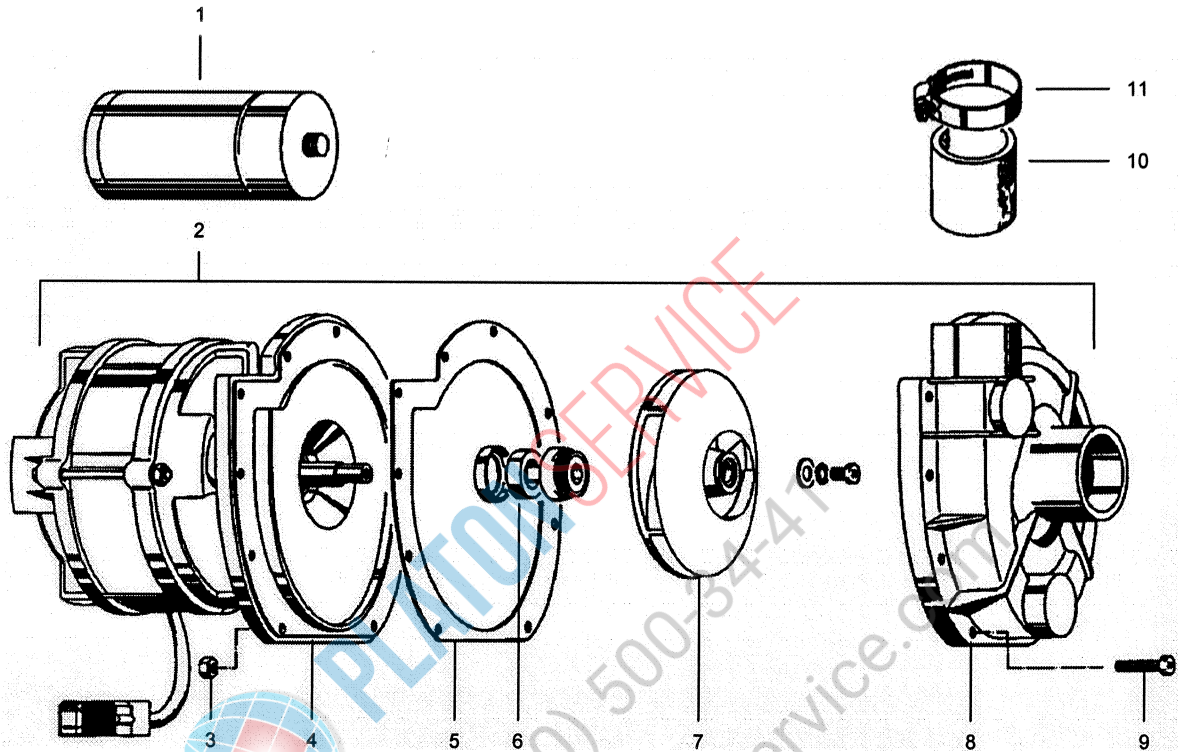

POS	IDENT. NR. IDENT. NO.	BEZEICHNUNG	DESIGNATION	DESIGNATION
1	* 9606122	KONDENSATOR 20 µF	CONDENSER 20 µF	CONDENSEUR 20 µF
2	* 9604594	PUMPE PU 0,7/2256, 0,75 KW 180-253V 50HZ	PUMP PU 0,7/2256, 0,75 KW 180-253V 50HZ	POMPE PU 0,7/2256, 0,75 KW 180-253V 50HZ
3	0335005	SECHSKANTMUTTER DIN 934 M 4	HEXAGON NUT DIN 934 M 4	ECROU A SIX PANS DIN 934 M 4
4	0501105	LAGERSCHILD MIT PUMPEN- DECKEL	END SHIELD WITH PUMP LID	FLASQUE AVEC COUVERCLE DE POMPE
5	* 0501094	PUMPENGEHÄUSEDICHTUNG	PACKING FOR PUMP HOUSING	JOINT POUR CORPS DE POMPE
6	V 0501095	GLEITRINGDICHTUNG KPL.	SLIDING SEAL COMPL.	JOINT AXIAL CPL.
7	* 9537022	PUMPENLAUFRAD	PUMP WHEEL	ROUE DE POMPE
8	0501091	PUMPENGEHÄUSE	PUMP HOUSING	CORPS DE POMPE
9	0303015	SECHSKANTSCHRAUBE DIN 933 M 4 X 25	HEXAGON SCREW DIN 933 M 4 X 25	VIS A SIX PANS DIN 933 M 4 X 25
10	0640007	SCHLAUCH SCHWARZ DIN 904 - Ø38 X 4	HOSE BLACK DIN 904 - Ø38 X 4	TUYAU FLEXIBLE NOIR DIN 904 - Ø38 X 4
11	0233046	SCHLAUCHKLEMME 32 - 50	HOSE CLAMP 32 - 50	PINCE/TUYAU SOUPLE 32 - 50
	0467004	TYPENSCHILD (NICHT GEZEICHNET)	LABEL (NOT DESIGNED)	PLAQUE AUTOCOLLANTE (NON DESIGNEE)
	8004160	MOTORKONSOLE	MOTOR CONSOLE	CONSOLE DE MOTEUR

02.05 PUMPENANSAUGUNG

02.05 PUMP SUCTIONING

02.05 ASPIRATION DE POMPE



Pu01_02c.doc
01.12.2000/FH

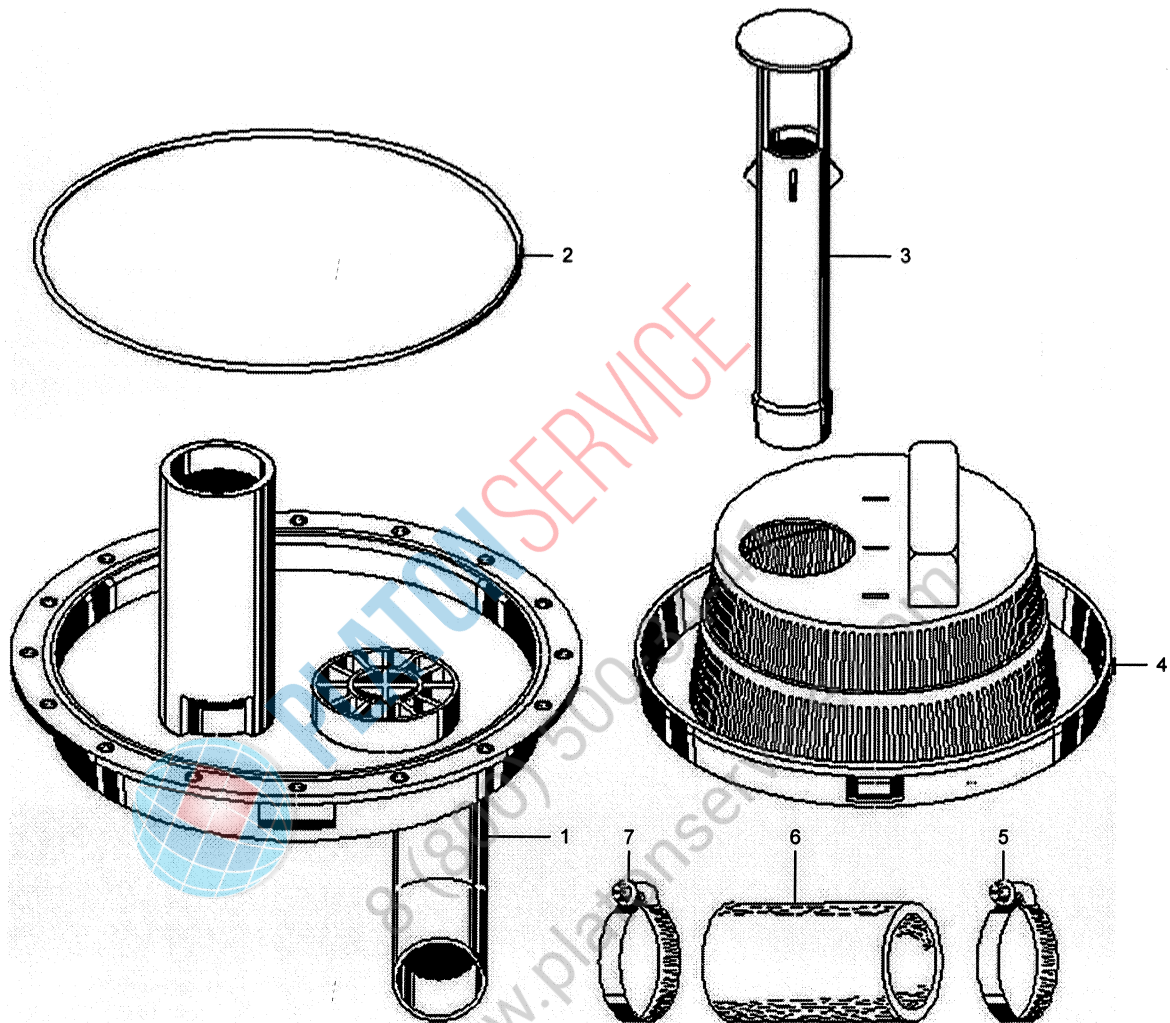

POS	IDENT. NR. IDENT. NO.	BEZEICHNUNG	DESIGNATION	DESIGNATION
1	8004720	PUMPENSUMPF MIT STANDROHR DV 40/80 T(FA)	PUMP SUMP WITH STAND PIPE DV 40/80 T(FA)	CUVETTE DE POMPE AVEC BONDE DE TROP PLEIN DV 40/80 T(FA)
2	* 0401061	O-RING 206,5 X 3,53	O-RING 206,5 X 3,53	BAGUE O 206,5 X 3,53
3	0620457	STANDROHR 255 LANG, K 413	STAND PIPE 255 LONG, K 413	BONDE DE TROP-PLEIN 255 LONG, K 413
4	0620346	SIEB MIT SCHMUTZRINNE K 337	FILTER WITH DIRT TRAP K 337	TAMIS AVEC PROFILE A DECHETS K 337
5	0233041	SCHLAUCHKLEMME 40 - 60	HOSE CLAMP 40 - 60	PINCE/TUYAU SOUPLE 40 - 60
6	8002454	SCHLAUCH GLASKLAR Ø35 X 5 X 70	HOSE TRANSPARENT Ø35 X 5 X 70	TUYAU FLEXIBLE TRANSPARENT Ø35 X 5 X 70
7	0233046	SCHLAUCHKLEMME 32 - 50	HOSE CLAMP 32 - 50	PINCE/TUYAU SOUPLE 32 - 50

03.25 WASCH- UND NACHSPÜLSYSTEM

03.25 WASHING AND RINSING SYSTEM

03.25 SYSTEME DE LAVAGE ET RINÇAGE



Wn3_19.doc
07.02.2002/BP

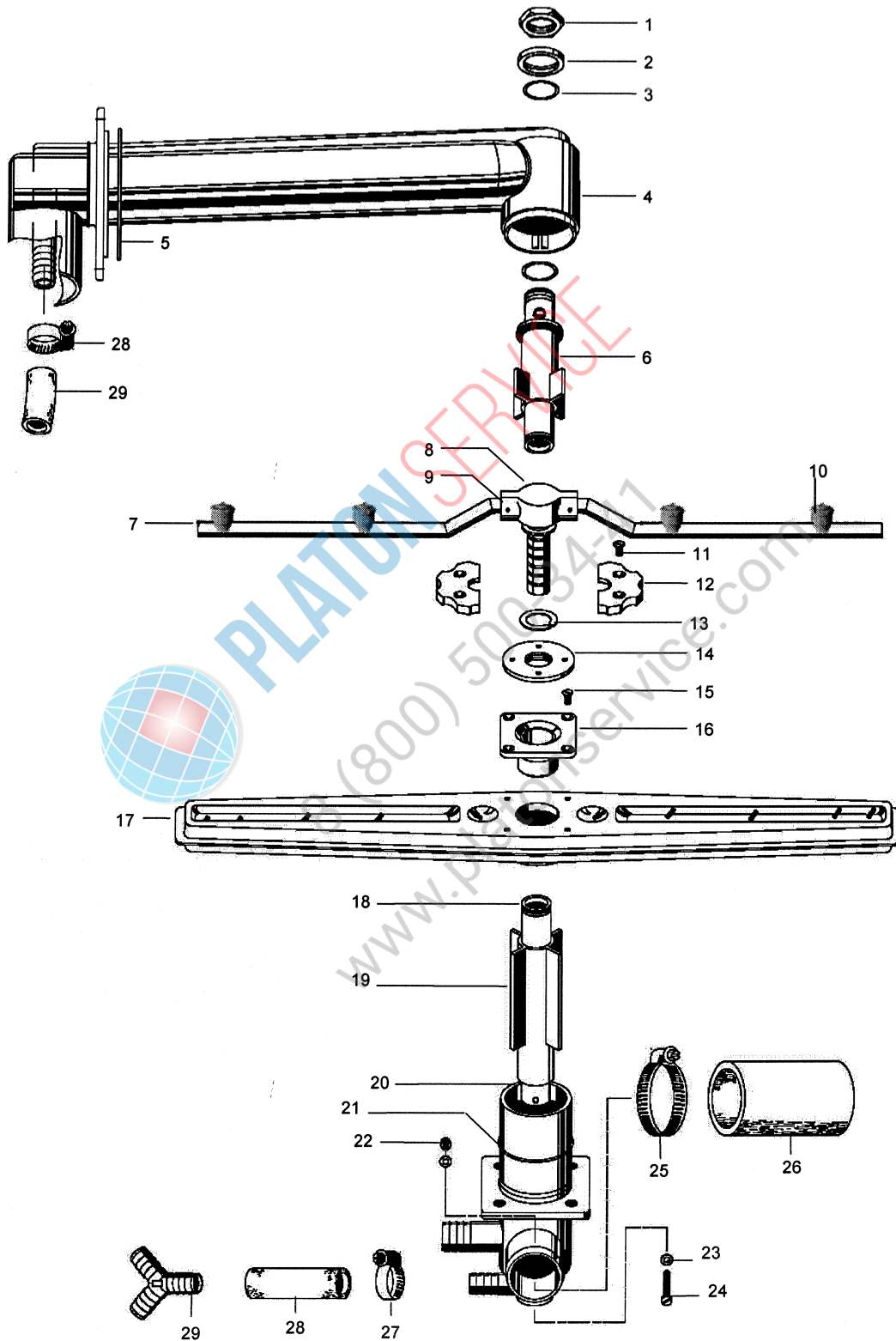

03.25 WASCH- UND NACHSPÜLSYSTEM

03.25 WASHING AND RINSING SYSTEM

03.25 SYSTEME DE LAVAGE ET RINÇAGE



Wn3_19.doc
07.02.2002/BP

POS	IDENT. NR. IDENT. NO.	BEZEICHNUNG	DESIGNATION	DESIGNATION
1	9550206	VERSCHLUSSKAPPE	CLOSING CAP	CAPOUCHON
2	8004468	DISTANZSCHEIBE	SPACER	PLAQUE D'ECARTEMENT
3	0401016	O-RING 21 X 2	O-RING 21 X 2	BAGUE O 21 X 2
4	8004454	STEIGROHR KPL. DV 80 T	ASCENDING PIPE COMPL. DV 80 T	TUYAU ASCENDANT COMPL. DV 80 T
4	8004481	STEIGROHR KPL. DV 120 T	ASCENDING PIPE COMPL. DV 120 T	TUYAU ASCENDANT COMPL. DV 120 T
5	0401065	O-RING 84 X 2	O-RING 84 X 2	BAGUE O 84 X 2
6	0620506	BEFESTIGUNGSROHR OBEN KPL.	UPPER FIXING TUBE COMPL.	TUYAU DE FIXATION SUPERIEUR COMPL.
7	9542558	NACHSPÜLDREHARM OBEN BAUGRUPPE	UPPER ROTATING RINSE ARM BLOCK	BRAS ROTATIF DE RINÇAGE SUP. BLOC
7	9542559	NACHSPÜLDREHARM UNTEN BAUGRUPPE	LOWER ROTATING RINSE ARM BLOCK	BRAS ROTATIF DE RINÇAGE INF. BLOC
8	* 8002880	LAGERZAPFEN K 242	BEARING BOLT K 242	TOURILLON K 242
9	0354000	KERBSTIFT DIN 1473 2 X 20	GROOVED PIN DIN 1473 2 X 20	GOUPILLE CANNELEE DIN 1473 2 X 20
10	* 9517406	NACHSPÜLDÜSE KPL.	RINSE NOZZLE CPL.	GICLEUR DERINÇAGE CPL.
11	0306005	SENKSCHRAUBE DIN 963 M4 X 6	FLAT HEAD SCREW DIN 963 M4 X 6	VIS A TETE CONIQUE DIN 963 M4 X 6
12	0620211	SCHEIBENHÄLFTE K 211	HALF DISK K 211	MOITIE DE DISQUE K 211
13	* 0403303	TEFLONRING 17 X 26 X 1	TEFLON RING 17 X 26 X 1	BAGUE EN TEFLON 17 X 26 X 1
14	8000049	MUTTER OBEN LINKSGEWINDE	UPPER NUT LEFT-HAND THREAD	ECROU SUPERIEUR FILETAGE A GAUCHE
14	8000048	MUTTER UNTEN RECHTSGEWINDE	LOWER NUT RIGHT-HAND THREAD	ECROU INFERIEUR FILETAGE A DROITE
15	0306006	SENKSCHRAUBE DIN 963 M4 X 8	FLAT HEAD SCREW DIN 963 M4 X 8	VIS A TETE CONIQUE DIN 963 M4 X 8
16	* 0620282	DREHARMNABE OBEN	UPPER ROTATING ARM HUB	MOYEU DE BRAS ROTATIF SUPER.
16	* 0620281	DREHARMNABE UNTEN	LOWER ROTATING ARM HUB	MOYEU DE BRAS ROTATIF INFER.
17	8000147	WASCHARM OBEN, BAUGRUPPE	UPPER WASH ARM, BLOCK	BRAS DE LAVAGE SUP., BLOC
17	8000146	WASCHARM UNTEN, BAUGRUPPE	LOWER WASH ARM, BLOCK	BRAS DE LAVAGE INF., BLOC
X	8004451	DREHARMLAGER UNTEN BAUGRUPPE	LOWER ROTATING ARM BEARING BLOCK	PALIER DE BRAS ROTATIF INF. BLOC
18	8000174	BEFESTIGUNGSROHR UNTEN	LOWER FIXING TUBE	TUYAU DE FIXATION INFERIEUR
19	0620233	ZENTRIERSTERN K 233	CENTERING DEVICE STAR K 233	ETOILE DE CENTRAGE K 233
20	0620443	DREHARMLAGER K 396	ROTATING ARM BEARING K 396	PALIER DE BRAS ROTATIF K 396
21	* 0401030	O-RING 50 X 1,5	O-RING 50 X 1,5	BAGUE O 50 X 1,5
22	0336001	HUTMUTTER DIN 1587 - M 4	CAP NUT DIN 1587 - M 4	ECROU BORGNE DIN 1587 - M 4
23	0409000	DICHTUNG 4 X 8 X 1	PACKING 4 X 8 X 1	JOINT 4 X 8 X 1
24	0308030	ZYLINDERSCHRAUBE DIN 84 M4 X 40	PAN HEAD SCREW DIN 84 M4 X 40	VIS A TETE CYLINDRIQUE DIN 84 M4 X 40
25	0233046	SCHLAUCHKLEMME 32 - 50	HOSE CLAMP 32 - 50	PINCE/TUYAU SOUPLE 32 - 50
26	8002454	SCHLAUCH KLARSICHT Ø35 X 5 X 70	TRANSPARENT HOSE Ø35 X 5 X 70	TUYAU TRANSPARENT Ø35 X 5 X 70
27	0233043	SCHLAUCHKLEMME 12 - 22	HOSE CLAMP 12 - 22	PINCE/TUYAU SOUPLE 12 - 22
28	0640012	SCHLAUCH GRAU 1/2"	HOSE GREY 1/2"	TUYAU FLEXIBLE GRIS 1/2"
29	* 0621036	Y-STÜCK YS 13	Y-PIECE YS 13	PIECE DE Y YS 13

04.08 MAGNETVENTIL

04.08 SOLENOID VALVE

04.08 ELECTROVANNE



EcoStar545 D
15.10.98/PT

Optional für Niederlande / optional for Netherlands / option pour les pays-bas

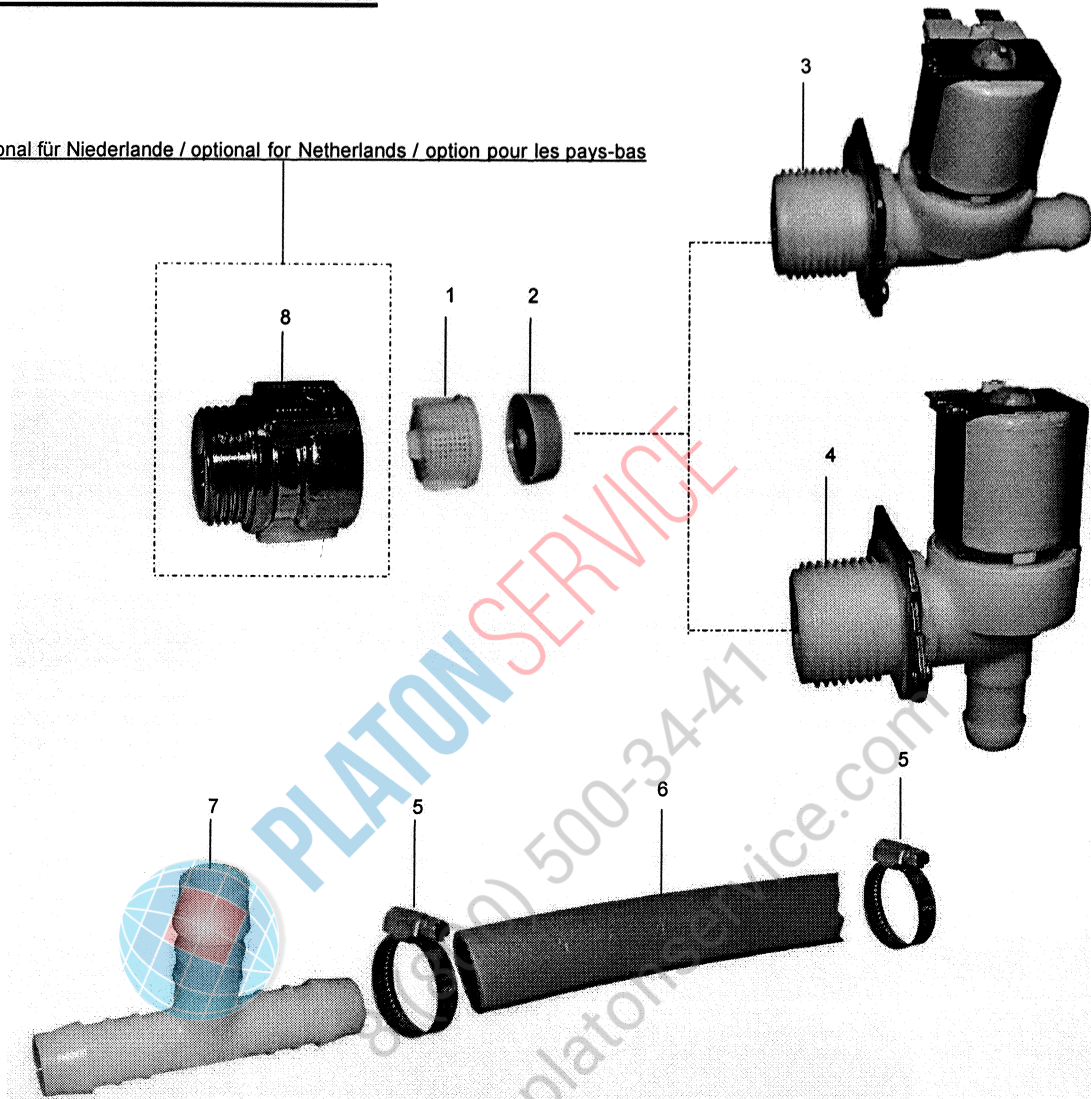

POS	IDENT. NR. IDENT. NO.	BEZEICHUNG	DESIGNATION	DESIGNATION
1	0113098	MAGNETVENTILFILTERSIEB	FILTER SIEVE F. SOLENOID VALVE	TAMIS-FILTRE P. ELECTROVANNE
2	9506227	MENGENREGLER 17 L/ MIN.	QUANTITY REGULATOR 17 L/MIN	REGULATEUR DE QUANTITE 17 L/MIN
3	* 9505869	MAGNETVENTIL NW 10 GERADE AUSFÜHRUNG ECOSTAR 530 F / 545 D	SOLENOID VALVE NW 10 LINEAR EXECUTION ECOSTAR 530 F / 545 D	ELECTROVANNE NW 10 EXÉCUTION LINÉAIRE ECOSTAR 530 F / 545 D
4	* 9000006	MAGNETVENTIL NW 10 ECKAUSFÜHRUNG ECOSTAR 430 F	SOLENOID VALVE NW 10 ANGLED EXECUTION ECOSTAR 430 F	ELECTROVANNE NW 10 EXECUTION EN ANGLE ECOSTAR 430 F
5	* 0233043	SCHLAUCHKLEMME 12 - 22	HOSE CLAMP 12 - 22	PINCE/TUYAU SOUPLE 12 - 22
6	* 0640012	SCHLAUCH GRAU 1/2"	HOSE GREY 1/2"	TUYAU FLEXIBLE GRIS 1/2"
7	0621035	T-STÜCK TS 13	T-PIECE TS 13	PIECE DE T TS 13
		OPTIONAL FÜR NIEDERLANDE	OPTIONAL FOR NETHERLANDS	OPTION POUR LES PAYS-BAS
7	9500454	RÜCKSCHLAGVENTIL 3/4"A X 3/4"l	CHECK VALVE 3/4"A X 3/4"l	CLAPET ANTI-RETOUR 3/4"A X 3/4"l

05.01 RÜCKSAUGEVERHINDERER

05.01 REFLUX PREVENTOR

05.01 DISPOSITIF ANTI-RETOUR

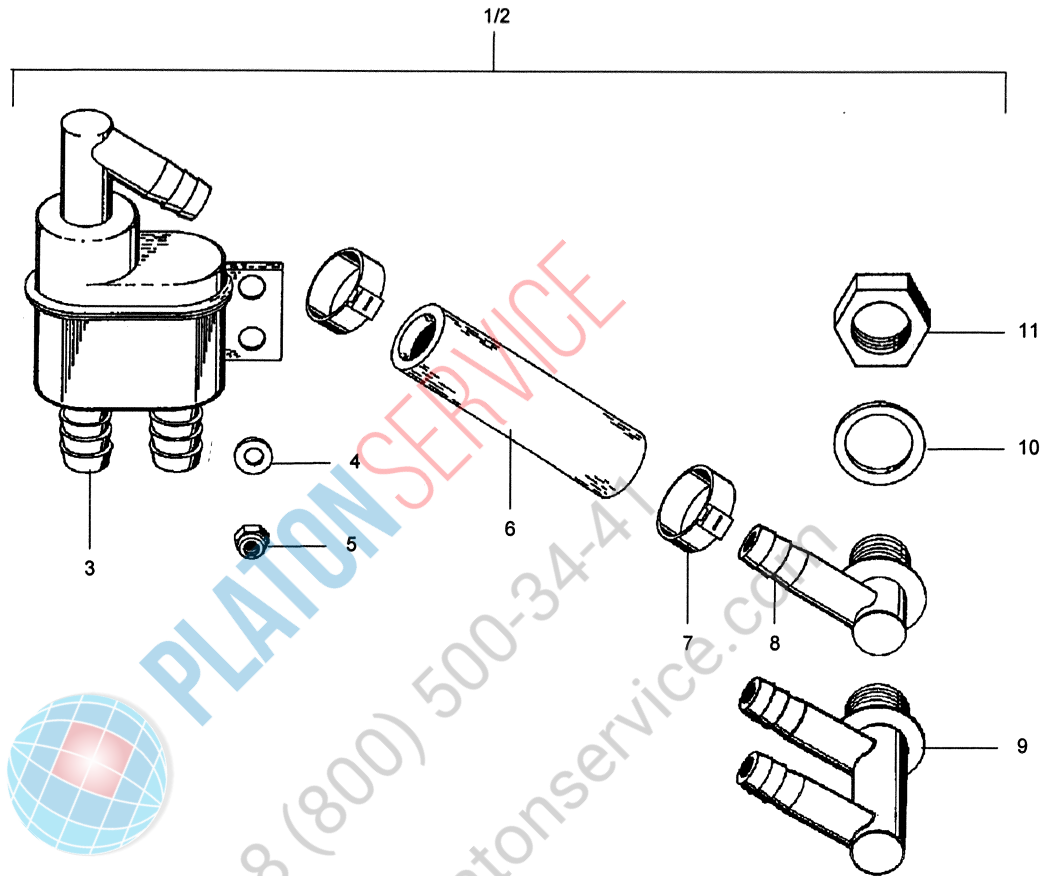

POS	IDENT. NR. IDENT. NO.	BEZEICHUNG	DESIGNATION	DESIGNATION
1	8002731	RÜCKSAUGEVERHINDERER 1/2" KPL. (OHNE EW)	REFLUX PREVENTOR 1/2" COMPL. (WITHOUT EW)	DISPOSITIF ANTI-RETOUR 1/2" COMPL. (SANS EW)
2	8002732	RÜCKSAUGEVERHINDERER 1/2" KPL. (MIT EW)	REFLUX PREVENTOR 1/2" COMPL. (WITH EW)	DISPOSITIF ANTI-RETOUR 1/2" COMPL. (AVEC EW)
3	* 0620334	RÜCKSAUGEVERHINDERER K 333	REFLUX PREVENTOR K 333	DISPOSITIF ANTI-RETOUR K 333
4	0340027	UNTERLEGSCHIEBE DIN 522 - 5,8 X 11 X 1	WASHER DIN 522 - 5,8 X 11 X 1	RONDELLE DIN 522 - 5,8 X 11 X 1
5	0337001	SECHSKANTMUTTER SELBST- SICHERND DIN 985 - M 5	HEXAGON NUT SELF-FIXING DIN 985 - M 5	ECROU A SIX PANS INDESSERRABLE DIN 985 - M 5
6	0640012	SCHLAUCH GRAU 1/2"	HOSE GREY 1/2"	TUYAU FLEXIBLE GRIS 1/2"
7	0233070	1-OHR-KLEMME	1-EAR CLAMP	BORNE A UNE OREILLE
8	* 0620342	SCHLAUCHANSCHLUSS EINFACH K 340	HOSE CONNECTION SIMPLE K 340	CONNEXION DE TUYAU SIMPLE K 340
9	* 0620343	SCHLAUCHANSCHLUSS DOPPELT K 341 (MIT EW)	HOSE CONNECTION DOUBLE K 340 (WITH EW)	CONNEXION DE TUYAU DOUBLE K 340 (AVEC EW)
10	* 0217433	GUMMIDICHTUNG 17 X 24 X 2	RUBBER PACKING 17 X 24 X 2	JOINT EN CAOUTCHOUC 17 X 24 X 2
11	0360211	SECHSKANTMUTTER R 3/8" X 5	HEXAGON NUT R 3/8" X 5	ECROU A SIX PANS R 3/8" X 5

06.08 NIVEAUREGELUNG

06.08 LEVEL CONTROL

06.08 REGULATION DE NIVEAU

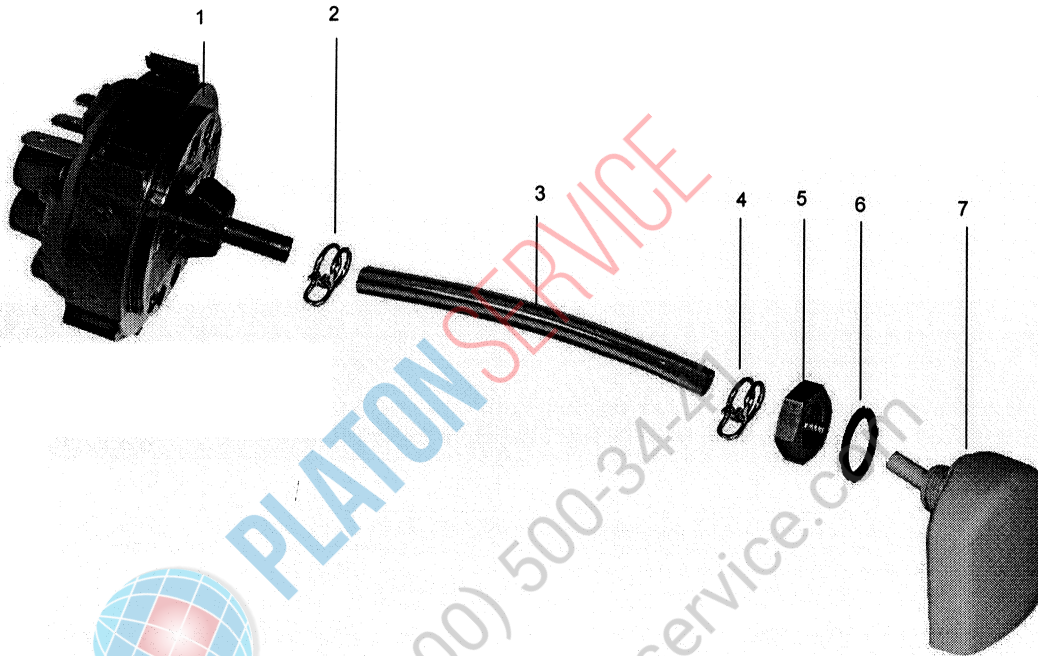

POS	IDENT. NR. IDENT. NO.	BEZEICHUNG	DESIGNATION	DESIGNATION
1	* 0130027	DRUCKSENSOR 90/25	LEVEL SWITCH 90/25	INTERRUPTEUR DE NIVEAU 90/25
2	* 9500044	SCHLAUCHKLEMME SILBER	HOSE WIRE CLAMP SILVER	COLLIER DE SERRAGE ARGENT
3	* 0260006	SCHLAUCH KLARSICHT Ø5	HOSE TRANSPARENT Ø5	TUYAU TRANSPARENT Ø5
4	* 9500045	SCHLAUCHKLEMME GELB	HOSE WIRE CLAMP YELLOW	COLLIER DE SERRAGE JAUNE
5	9515957	MUTTER 3/8"	NUT 3/8"	ECROU 3/8"
6	* 9515964	DICHTUNG	PACKING	JOINT
7	* 9515955	LUFTFALLE	AIR TRAP	CHAMBRE DE COMPRESSION

08.25 EINBAUBOILER

08.25 INCORPORATED BOILER

08.25 SURCHAUFFEUR INCORPORE

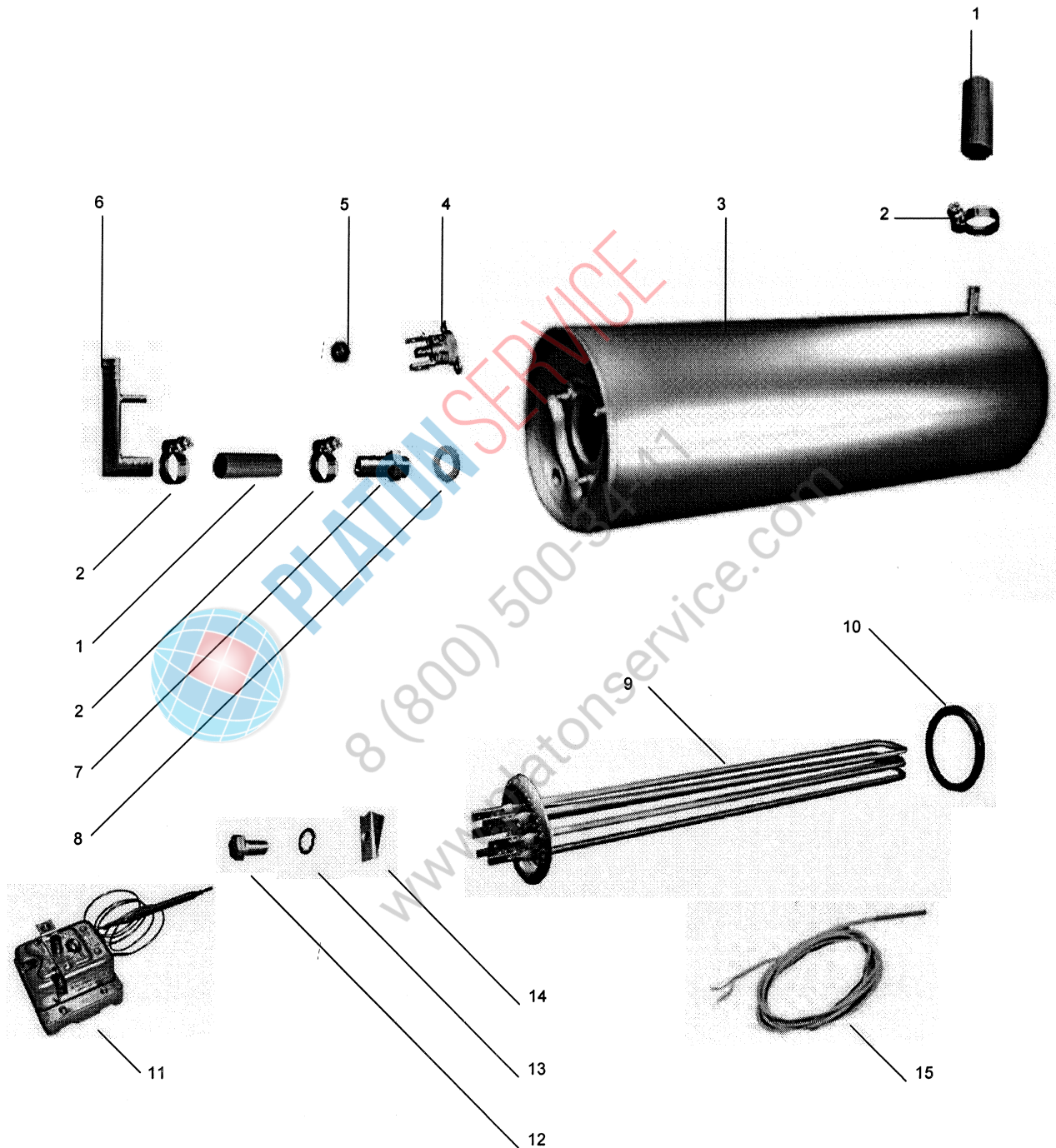

08.25 EINBAUBOILER

08.25 INCORPORATED BOILER

08.25 SURCHAUFFEUR INCORPORE



BH8_25.doc
01.12.200/Fh

POS	IDENT. NR. IDENT. NO.	BEZEICHNUNG	DESIGNATION	DESIGNATION
1	* 0640012	SCHLAUCH GRAU 1/2"	HOSE GREY 1/2"	TUYAU FLEXIBLE GRIS 1/2"
2	* 0233037	SCHLAUCHKLEMME 16 - 27	HOSE CLAMP 16 - 27	PINCE/TUYAUX SOUPLES 16 - 27
3	8400269	EINBAUBOILERGEHÄUSE ABGEPRESST	BOILER HOUSING TESTED UNDER PRESSURE	BOITE DE SURCHAUFFEUR VERIFIER SOUS PRESSION
4	* 0108038	TEMPERATURBEGRENZER 105 GRAD, 1 KONTAKT	TEMPERATURE LIMITER 105 DEGREES, 1 CONTACT	LIMITEUR DE TEMPERATURE 105 DEGRES, 1 CONTACT
5	0335000	SECHSKANTMUTTER DIN 934 - M 3	HEXAGON NUT DIN 934 - M 3	ECROU A SIX PANS DIN 934 - M 3
6	0620373	SCHLAUCHANSCHLUSSWINKEL K 368	HOSE CONNECTION ANGLE K 368	ANGLE DE CONNEXION DE TUYAUX K 368
7	0360202	SCHLAUCHANSCHLUSS	HOSE CONNECTION	CONNEXION DE TUYAUX
8	* 0408008	DICHTUNG 25 X 14 X 1,5	PACKING 25 X 14 X 1,5	JOINT 25 X 14 X 1,5
9	* 9504228	TOPFFLANSCHHEIZKÖRPER 3 KW, 230/400 V	FLANGE HEATING ELEMENT 3 KW, 230/400 V	RESISTANCE A BRIDE 3 KW, 230/400 V
	* 9504234	TOPFFLANSCHHEIZKÖRPER 4,5 KW, 230/400 V	FLANGE HEATING ELEMENT 4,5 KW, 230/400 V	RESISTANCE A BRIDE 4,5 KW, 230/400 V
	* 9504236	TOPFFLANSCHHEIZKÖRPER 6 KW, 230/400 V	FLANGE HEATING ELEMENT 6 KW, 230/400 V	RESISTANCE A BRIDE 6 KW, 230/400 V
	* 9504237	TOPFFLANSCHHEIZKÖRPER 7,5 KW, 230/400 V	FLANGE HEATING ELEMENT 7,5 KW, 230/400 V	RESISTANCE A BRIDE 7,5 KW, 230/400 V
	* 9504240	TOPFFLANSCHHEIZKÖRPER 9 KW, 230/400 V	FLANGE HEATING ELEMENT 9 KW, 230/400 V	RESISTANCE A BRIDE 9 KW, 230/400 V
	* 9500498	TOPFFLANSCHHEIZKÖRPER 12 KW, 230/400 V	FLANGE HEATING ELEMENT 12 KW, 230/400 V	RESISTANCE A BRIDE 12 KW, 230/400 V
10	* 0101176	HEIZKÖRPERDICHTUNG 58 X 45 X 6	PACKING F. HEATING ELEMENT 58 X 45 X 6	JOINT DE RESISTANCE 58 X 45 X 6
11	* 9502526	TEMPERATURBEGRENZER 120 GRAD, 3 KONTAKTE	TEMPERATURE LIMITER 120 DEGREES, 3 CONTACTS	LIMITEUR DE TEMPERATURE 120 DEGRES, 3 CONTACTS
12	0302048	SECHSKANTSCHRAUBE DIN 933 - M 5 X 8	HEXAGON SCREW DIN 933 - M 5 X 8	VIS A SIX PANS DIN 933 - M 5 X 8
13	0342010	ZAHNSCHEIBE DIN 6797 - J 5,3	TOOTH LOCK WASHER DIN 6797 - J 5,3	DISQUE A FENTES DIN 6797 - J 5,3
14	0101183	SPANNBRÜCKE	GRIPPING YOKE	PONT DE TENSION
15	* 9500236	TEMPERATURFÜHLER Ø 6X50 SI	TEMPERATURE PROBE Ø 6X50 SI	SONDE DE TEMPERATURE Ø 6X50 SI
	8400259	EINBAUBOILER KPL. 3 KW	INCORPORATED BOILER COMPL. 3 KW	SURCHAUFFEUR INCORPORE COMPL. 3 KW
	8400260	EINBAUBOILER KPL. 6 KW	INCORPORATED BOILER COMPL. 6 KW	SURCHAUFFEUR INCORPORE COMPL. 6 KW
	8400261	EINBAUBOILER KPL. 7,5 KW	INCORPORATED BOILER COMPL. 7,5 KW	SURCHAUFFEUR INCORPORE COMPL. 7,5 KW
	8400229	EINBAUBOILER KPL. 9 KW	INCORPORATED BOILER COMPL. 9 KW	SURCHAUFFEUR INCORPORE COMPL. 9 KW

09.05 TANKHEIZUNG

09.05 TANK HEATING

09.05 CHAUFFAGE DE BAC

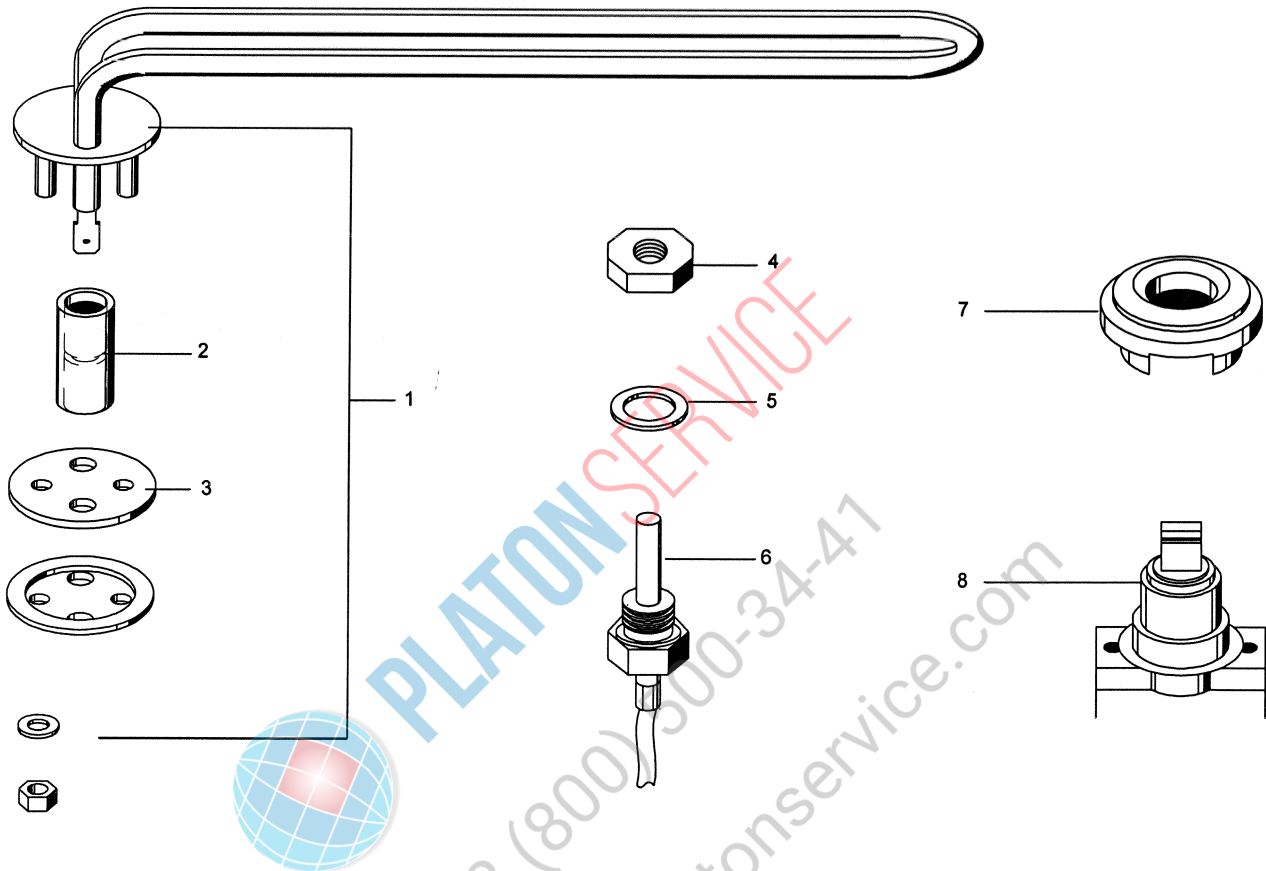

POS	IDENT. NR. IDENT. NO.	BEZEICHNUNG	DESIGNATION	DESIGNATION
1	* 0101152	HEIZKÖRPER 2 KW, 230 V	HEATING ELEMENT 2 KW, 230 V	RESISTANCE 2 KW, 230 V
2	9543319	BERÜHRUNGSSCHUTZ	PROTECTION AGAINST CONTACT	PROTECTION CONTRE CONTACT
3	* 0101175	HEIZKÖRPERDICHTUNG	HEATING ELEMENT PACKING	JOINT DE RESISTANCE
4	* 0212012	SECHSKANTMUTTER 1.4301 DIN 431 R1/4"	HEXAGON NUT 1.4301 DIN 431 R1/4"	ECROU HEXAGONAL 1.4301 DIN 431 R1/4"
5	* 0408227	DICHTUNG 19 X 13	PACKING 19 X 13	JOINT 19 X 13
6	* 0180682	TEMPERATURFÜHLER R1/4"	TEMPERATURE PROBE R1/4"	SONDE DE TEMPERATURE R1/4"
7	* 0108040	GUMMIMANSCHETTE	RUBBER PACKING	MANCHETTE EN CAOUTCHOUC
8	* 0108043	TEMPERATURBEGRENZER	TEMPERATURE LIMITER	LIMITEUR DE TEMPÉRATURE

10.07 KLARSPÜLERDOSIERUNG

10.07 RINSE AID DOSING UNIT

10.07 DOSEUR DE PRODUIT TENSIO-ACTIF

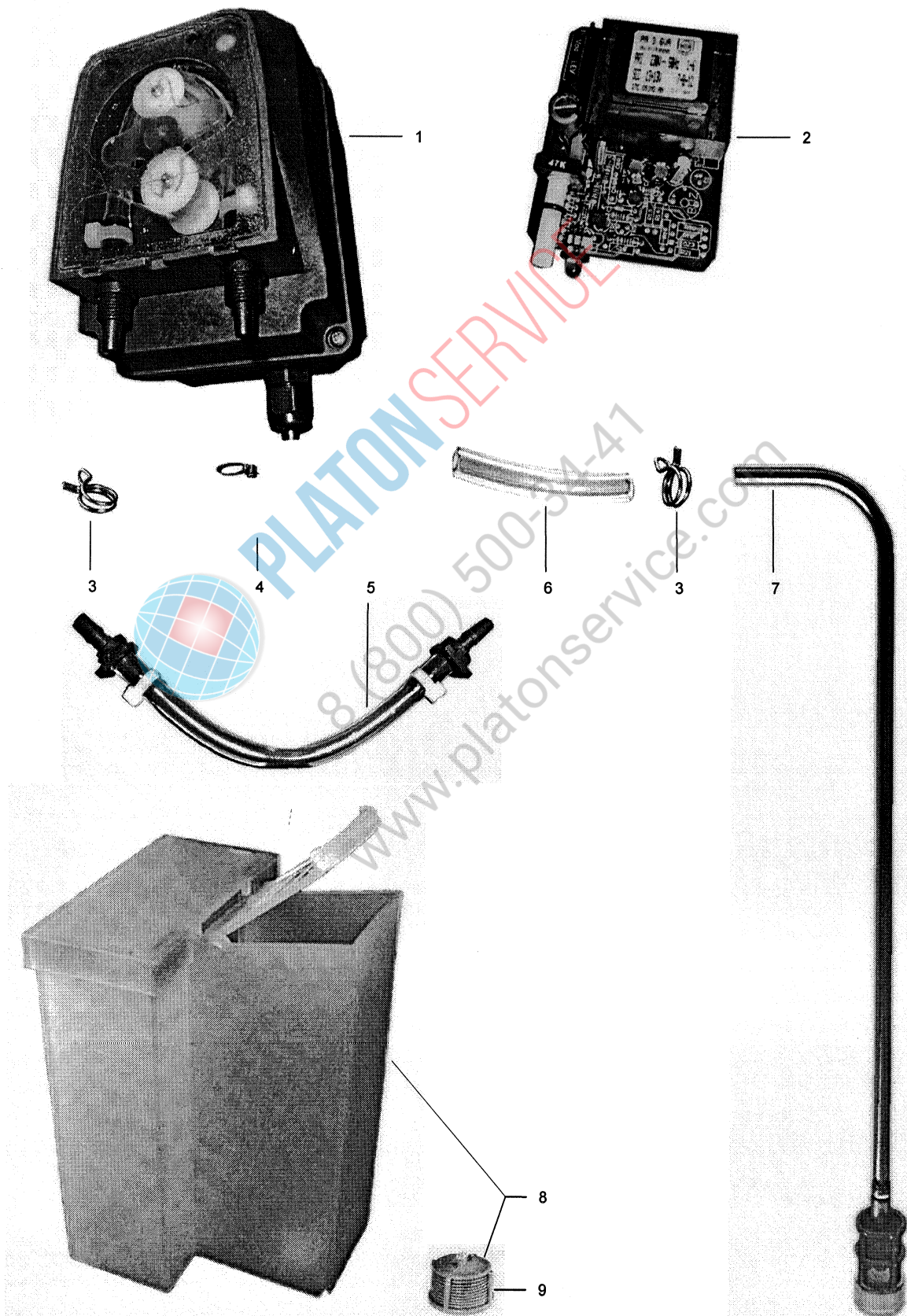

10.07 KLARSPÜLERDOSIERUNG

10.07 RINSE AID DOSING UNIT

10.07 DOSEUR DE PRODUIT TENSIO-ACTIF



DOS10_7.doc
01.12.2000/FH

POS	IDENT. NR. IDENT. NO.	BEZEICHNUNG	DESIGNATION	DESIGNATION
1	* 9503331	KLARSPÜLERDOSIERGERÄT PR1, 230 V, 50 HZ	RINSE AID DOSING UNIT PR1, 230 V, 50 HZ	DOSEUR DE PRODUIT TENSIO- ACTIF PR1, 230 V, 50 HZ
2	9505653	DREHZAHLREGELUNG	SPEED CONTROL	REGULATEUR DE VITESSE
3	* 9500045	DRAHTSCHLAUCHKLEMME 8,8 - 9,3 MM	HOSE WIRE CLAMP 8,8 - 9,3 MM	COLLIER DE SERRAGE 8,8 - 9,3 MM
4	* 0233036	SCHLAUCHKLEMME 10 - 16	HOSE CLAMP 10 - 16	PINCE/TUYAUX SOUPLES 10 - 16
5	* 9505652	DOSIERSCHLAUCH 1 L/H SILIKON	DOSING HOSE 1 L/H SILICON	TUYAU POUR DOSEUR 1 L/H SILICONE
6	V 0260007	SCHLAUCH KLARSICHT 6 X 1,5	HOSE TRANSPARENT 6 X 1,5	TUYAU TRANSPARENT 6 X 1,5
6	0640017	SCHLAUCH SCHWARZ 6 X 4,5	HOSE BLACK 6 X 4,5	TUYAU NOIR 6 X 4,5
7	8005393	ANSAUGROHR, 340 MM	SUCTION TUBE, 340 MM	CONDUITE D'ASPIRATION 340 MM
7	8005372	ANSAUGROHR, 420 MM	SUCTION TUBE, 420 MM	CONDUITE D'ASPIRATION 420 MM
8	8003830	KLARSPÜLERBEHÄLTER K 376	RINSE AID CONTAINER K 376	CONTENEUR DE PRODUIT TENSIO-ACTIF K 376
9	0113098	MAGNETVENTILFILTERSIEB	FILTER FOR SOLENOID VALVE	TAMIS-FILTRE D'ELECTROVANNE
X	9504799	RÜCKSCHLAGVENTIL	CHECK VALVE	CLAPET ANTI-RETOUR



PLATON SERVICE
8 (800) 500-34-17
www.platonservice.com

11.41 ELEKTRONIKSTEUERUNG

11.41 ELECTRONIC CONTROL

11.41 COMMANDE ELECTRONIQUE



EcoStar545 D
07.02.02/BP

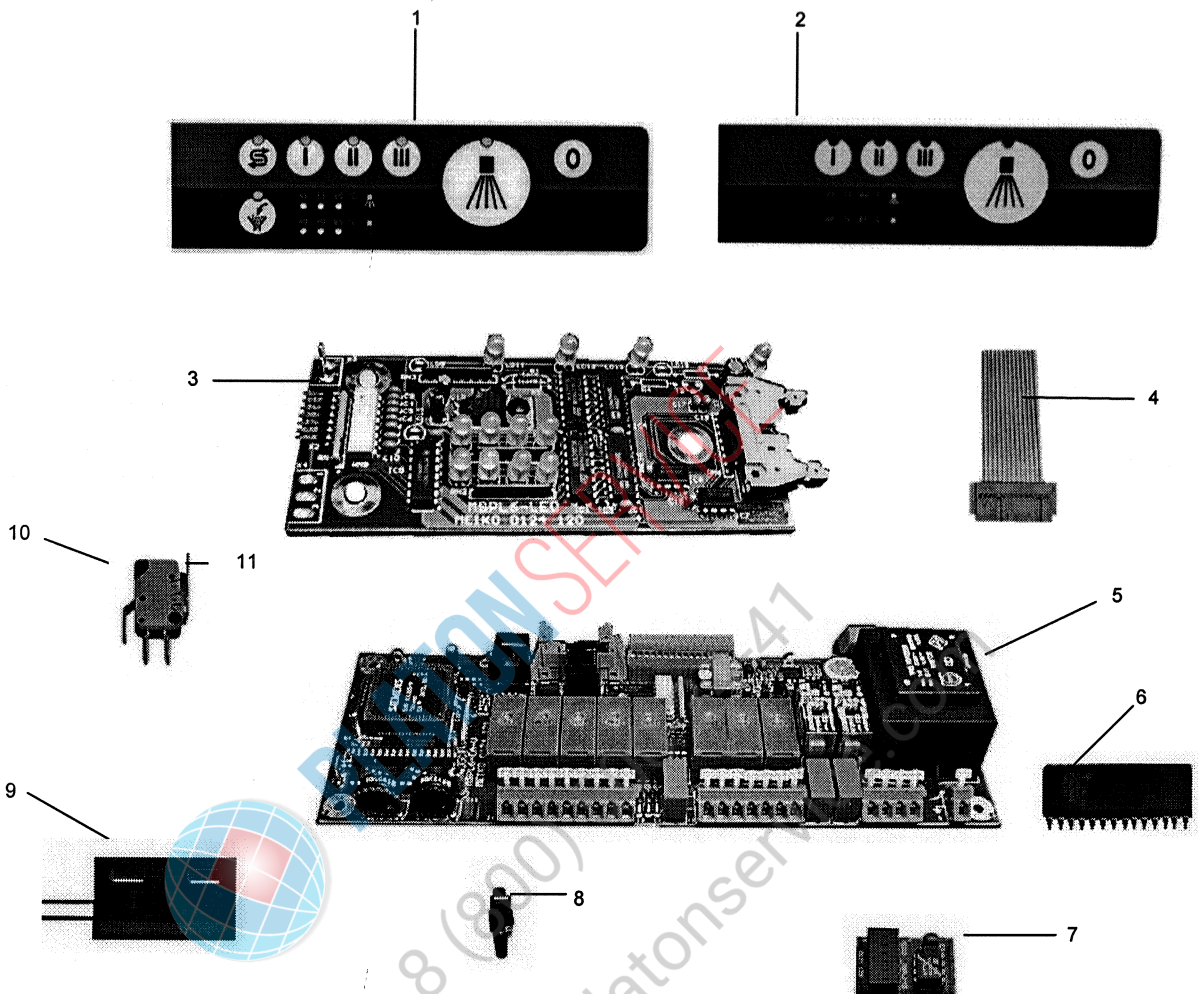

POS	IDENT. NR. IDENT. NO.	BEZEICHNUNG	DESIGNATION	DESIGNATION
1	9542382	FOLIENASTATUR - EW	SENSOR TOUCH PANEL - EW	CLAVIER SENSITIF - EW
2	* 9542402	FOLIENASTATUR	SENSOR TOUCH PANEL	CLAVIER SENSITIF
3	* 9532115	DIODENPLATINE MSPL6-LED	DIODE CIRCUIT BOARD	PLATINE A DIODES
4	* 0180507	FLACHBANDKABEL M. STECKER 14 POL. 0,8 M	RIBBON CABLE WITH PLUG	CABLE PLAT AVEC FICHE
5	* 9519719	STEUERPLATINE MSPL6-EA-V	CONTROL BOARD MSPL6-EA-V	PLATINE A COMMANDE MSPL6-EA-V
6	* 0124351	EPROM MSPL6-STD	EPROM MSPL6-STD	EPROM MSPL6-STD
7	* 9534803	EEPROM MSPL6-EE NICHT PROGRAMMIERT	EEPROM MSPL6-EE NOT PROGRAMMED	EEPROM MSPL6-EE NON-PROGRAMME
8	0175553	ABSTANDHALTER	SPREADER	ECARTEUR
9	0122070	MAGNETSCHALTER	MAGNET SWITCH	INTERRUPTEUR MAGNETIQUE
10	* 9544800	MICROSCHALTER	MICROSWITCH	MICRORUPTEUR
11	* 0122106	HEBEL	LEVER	LEVIER
	* 9500236	TEMPERATURFÜHLER Ø6 X 50 (BOILER)	TEMPERATURE PROBE	SONDE DE TEMPERATURE
	* 0180682	TEMPERATURFÜHLER R¼"(TANK)	TEMPERATURE PROBE (TANK)	SONDE DE TEMPERATURE (BAC)

12.10 ELEKTROTEILE

12.10 ELECTRICAL PARTS

12.10 PIECES ELECTRIQUE



E12_10.doc
02.07.2002/BP

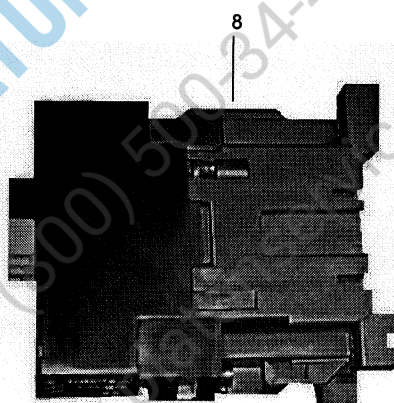
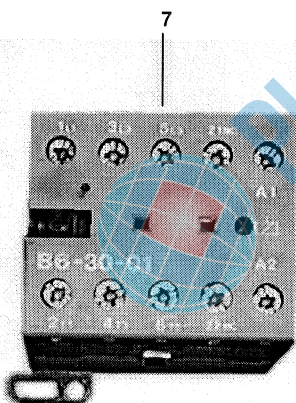
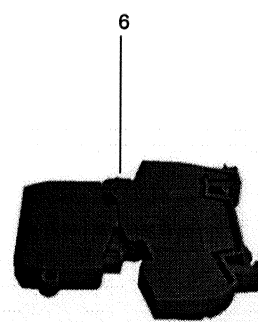
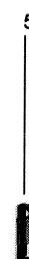
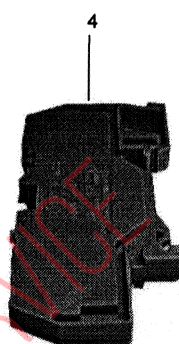
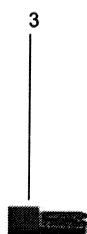
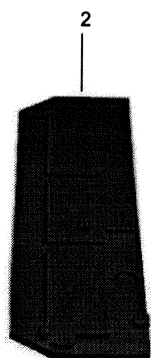
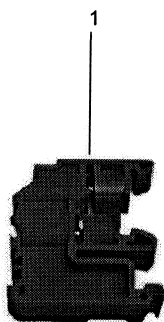

12.10 ELEKTROTEILE

12.10 ELECTRICAL PARTS

12.10 PIÈCES ELECTRIQUE



E112_10.doc
02.07.2002/BP

POS	IDENT. NR. IDENT. NO.	BEZEICHNUNG	DESIGNATION	DESIGNATION
1	0153288	ENDHALTER	FINAL HOLDER	SUPPORT FINAL
2	0153071	ABSCHLUß- UND ZWISCHEN- PLATTE 2,5QMM GRAU	BINDER END COVER 2,5QMM GREY	COUVERCLE DE FERMETURE POUR BORNE, 2,5QMM GRIS
2	0153080	ABSCHLUß- UND ZWISCHEN- PLATTE 4QMM GRAU	BINDER END COVER 4QMM GREY	COUVERCLE DE FERMETURE POUR BORNE, 4QMM GRIS
2	0153128	ABSCHLUß- UND ZWISCHEN- PLATTE 6QMM GRAU	BINDER END COVER 6QMM GREY	COUVERCLE DE FERMETURE POUR BORNE, 6QMM GRIS
3	0153091	QUERBRÜCKER 4QMM	CROSS BRIDGE 4QMM	CONTACT DE PONTAGE 4QMM
3	0153126	QUERBRÜCKER 6QMM	CROSS BRIDGE 6QMM	CONTACT DE PONTAGE 6QMM
4	0153060	KLEMME 3-LEITER 4QMM GRAU	BINDER 3 CONDUCTORS 4QMM GREY	BORNE 3 CONDUCTEURS 4QMM GRIS
4	0153127	KLEMME 3-LEITER 4QMM BLAU	BINDER 3 CONDUCTORS 4QMM BLUE	BORNE 3 CONDUCTEURS 4QMM BLEUE
4	0153132	KLEMME 3-LEITER 4QMM GELB/GRÜN	BINDER 3 CONDUCTORS 4QMM YELLOW/GREEN	BORNE 3 CONDUCTEURS 4QMM JAUNE/VERTE
4	0153129	KLEMME 3-LEITER 6QMM GRAU	BINDER 3 CONDUCTORS 6QMM GREY	BORNE 3 CONDUCTEURS 6QMM GRIS
4	0153131	KLEMME 3-LEITER 6QMM BLAU	BINDER 3 CONDUCTORS 6QMM BLUE	BORNE 3 CONDUCTEURS 6QMM BLEUE
4	0153130	KLEMME 3-LEITER 6QMM GELB/GRÜN	BINDER 3 CONDUCTORS 6QMM YELLOW/GREEN	BORNE 3 CONDUCTEURS 6QMM JAUNE/VERTE
4	0153042	KLEMME 4-LEITER 2,5QMM GRAU	BINDER 4 CONDUCTORS 2,5QMM GREY	BORNE 4 CONDUCTEURS 2,5QMM GRIS
4	9505881	KLEMME 4-LEITER 2,5QMM BLAU	BINDER 4 CONDUCTORS 2,5QMM BLUE	BORNE 4 CONDUCTEURS 2,5QMM BLEUE
4	9505882	KLEMME 4-LEITER 2,5QMM GELB/GRÜN	BINDER 4 CONDUCTORS 2,5QMM YELLOW/GREEN	BORNE 4 CONDUCTEURS 2,5QMM JAUNE/VERTE
5	* 0145013	FEINSICHERUNG 4A MITTELTRÄGE 5 X 20	FINE-WIRE FUSE 4A TIME LAGGED 5 X 20	FUSIBLE P.FAIBLE INTENSITE 4A A ACTION RETARDEE 5 X 20
5	* 0145000	FEINSICHERUNG 10A MITTELTRÄGE 5 X 20	FINE-WIRE FUSE 10A TIME LAGGED 5 X 20	FUSIBLE P.FAIBLE INTENSITE 10A A ACTION RETARDEE 5 X 20
6	0153054	SICHERUNGSKLEMME	SAFETY CLAMP	BORNE DE SECURITE
7	* 0135200	SCHÜTZ B6-30-10 230 V 40/60 HZ	CONTACTOR B6-30-10 230 V 40/60 HZ	CONTACTEUR B6-30-10 230 V 40/60 HZ
7	* 0135209	SCHÜTZ B6-30-01 230 V 40/60 HZ	CONTACTOR B6-30-01 230 V 40/60 HZ	CONTACTEUR B6-30-01 230 V 40/60 HZ
8	* 9520025	SCHÜTZ A9-30-01 230 V 50/60 HZ	CONTACTOR A9-30-01 230 V 50/60 HZ	CONTACTEUR A9-30-01 230 V 50/60 HZ
8	* 9520024	SCHÜTZ A12-30-01 230 V 50/60 HZ	CONTACTOR A12-30-01 230 V 50/60 HZ	CONTACTEUR A12-30-01 230 V 50/60 HZ

13.13 BAUGRUPPEN / EINZELTEILE

13.13 COMPONENT BLOCKS / PARTS

13.13 BLOCS / PIECES DETACHES



POS	IDENT. NR. IDENT. NO.	BEZEICHNUNG	DESIGNATION	DESIGNATION
	8004127	HAUBE KPL.	HOOD COMPL.	CAPOT COMPL.
	0463052	HAUBENFÜHRUNG RECHTS	HOOD ROD RIGHT HAND SIDE	BARRE DE CAPOT DROITE
	0463053	HAUBENFÜHRUNG LINKS	HOOD ROD LEFT HAND SIDE	BARRE DE CAPOT GAUCHE
	8004149	KORBTRÄGER KPL.	BASKET GUIDE RAIL COMPL.	SUPPORT DE PANIERS COMPL.
	8004406	TANKSIEB LINKS	TANK SIEVE LEFT HAND SIDE	TAMIS FILTRE GAUCHE
	0251102	TANKSIEB RECHTS	TANK SIEVE RIGHT HAND SIDE	TAMIS FILTRE DROITE
	8004467	SCHLIEßBLECH LINKS	STRIKE PLATE	TOLE DE FERMETURE
	8004141	SEITENVERKLEIDUNG	SIDE CLADDING	REVETEMENT LATERAL
	8004142	FRONTVERKLEIDUNG	FRONT CLADDING	REVETEMENT FRONTAL
	8004137	FEDERKASTENABDECKUNG	SPRING HOUSING COVER	RECOUVREMENT DE LA BOITE DES RESSORTS
	8004156	RÜCKWAND KPL.	REAR CLADDING COMPL.	REVETEMENT ARRIERE COMPL.
	0620455	ABSTANDHALTER FÜR VERKLEIDUNGEN	SPACER FOR CLADDING	ECARTEUR POUR REVETEMENT
	9500378	TISCHSTOLLEN KPL.	TABLE LEGS CPL.	PIEDS DE TABLE CPL.
	0495440	UNIVERSALKORB VKV 50/1	UNIVERSAL BASKET VKV 50/1	PANIER UNIVERSEL VKV 50/1
	0495445	KLEINTEILEKORB VKV 50/2	BASKET FOR SMALL PIECES VKV 50/2	PANIER A PETITES PIECES VKV 50/2
	0640040	PANZERSCHLAUCH 1/2" X 2000	REINFORCED HOSE 1/2" X 2000	TUYEAU RENFORCÉ 1/2" X 2000
	9500011	PANZERSCHLAUCH 1/2" X 2000 WRC ZULASSUNG	REINFORCED HOSE 1/2" X 2000 WRC-APPROVED	TUYEAU RENFORCE 1/2" X 2000 CERTIFIE WRC

14.08 HAUBENGESTÄNGE

14.08 HOOD ROD

14.08 BARRE DE CAPOT



Hg14_8.doc
01.12.2002/BP

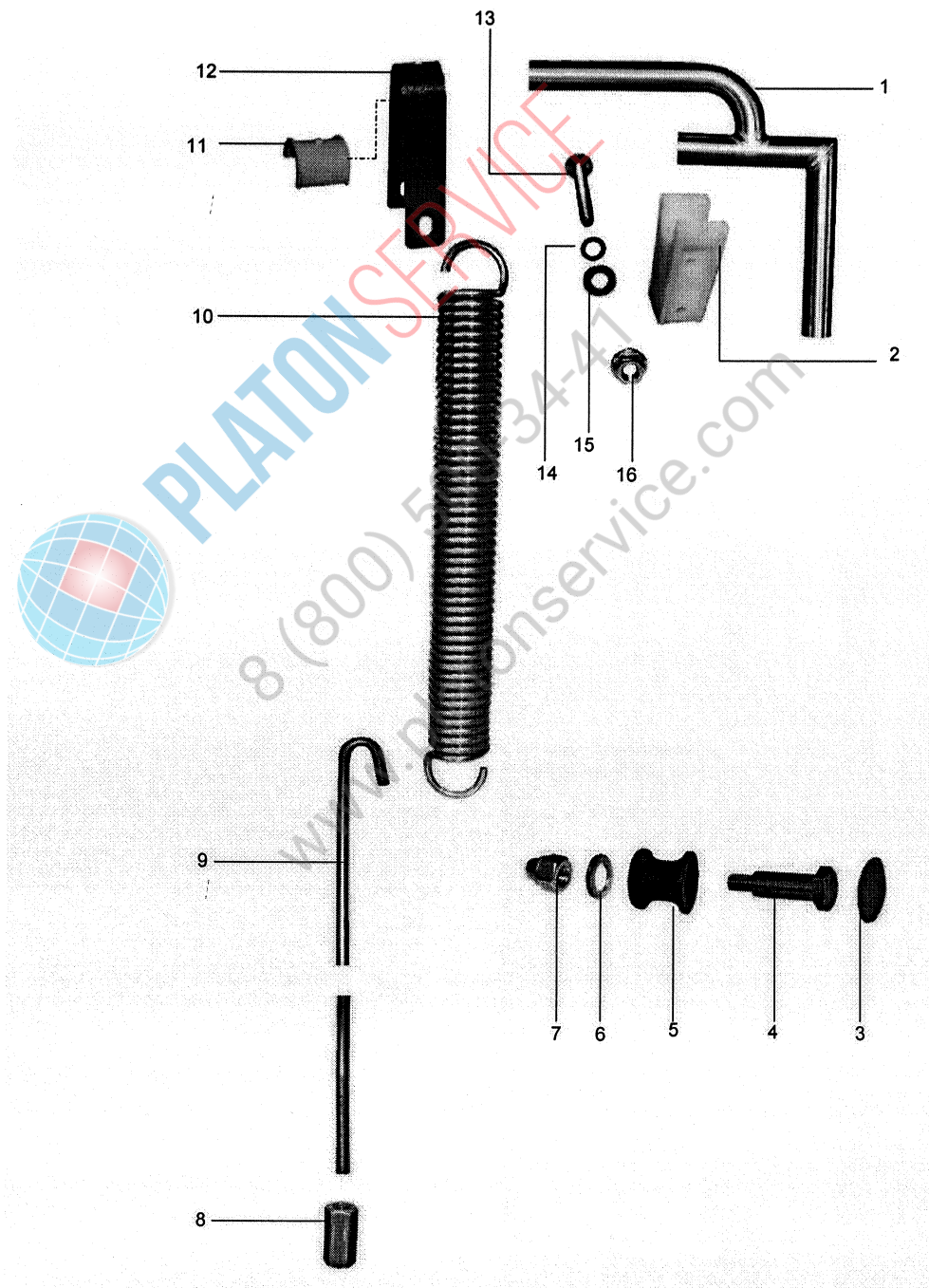

14.08 HAUBENGESTÄNGE

14.08 HOOD ROD

14.08 BARRE DE CAPOT



Hg14_8.doc
01.12.2002/BP

POS	IDENT. NR. IDENT. NO.	BEZEICHNUNG	DESIGNATION	DESIGNATION
1	0251103	HAUBENGESTÄNGE DV 80 T	HOOD ROD DV 80 T	BARRE DE CAPOT DV80 T
2	0620449	LAGERUNG FÜR HAUBEN- GESTÄNGE	HOOD ROD BEARING	COUSSINET POUR BARRE DE CAPOT
3	8004480	DECKEL FÜR HAUBENROLLE	HOOD ROLLER COVER	COUVERDE P. GALET DE CAPOT
4	8000220	ROLLENBOLZEN SW 17 X 51 - M 8	ROLLER BOLT SW 17 X 51 - M 8	BOULON A ROULEAUX SW 17 X 51 - M 8
5	0620451	HAUBENROLLE K 409	HOOD ROLLER K 409	GALET DE CAPOT K 409
6	0340006	U-SCHEIBE 8,4 X 18 X 2	FRONT DISC 8,4 X 18 X 2	RONDELLE 8,4 X 18 X 2
7	0337005	HUTMUTTER SELBST- SICHERND, M 8	CAP NUT SELFLOCKING M 8	ECROU BORGNE, INDESSER- RABLE, M 8
8	8004147	SPANNMUTTER M 8	TENSION NUT M 8	ECROU TENDEUR M 8
9	* 8004425	SPANNSCHRAUBE M 8 760 LANG	TENSION SCREW M 8 760 LONG	VIS DE TENSION M 8 760 LONG
10	* 0430006	ZUGFEDER 372 X 46,5 X 6,5	TENSION SPRING 372 X 46,5 X 6,5	RESSORT DE TRACTION 372 X 46,5 X 6,5
11	0620445	GLEITLAGER FEDERAUF- HÄNGUNG K 399	SLIDING BEARING FOR SPRING SUSPENSION K 399	PALIER-GLISSEUR POUR SUSP. DE RESSORT SUP. K 399
12	8004144	FEDERAUFHÄNGUNG OBEN	UPPER SPRING SUSPENDER	SUSPENDEUR DE RESSORT SUP.
13	9541450	LINSENSCHRAUBE	OVAL HEAT SCREW	VIS A TETE BOMBEE
14	9541531	O-RING 6X2	O-RING 6X2	BAGUE 6X2
15	0340005	U-SCHEIBE 10,5 X 18 X 1,6	FRONT DISC 10,5 X 18 X 1,6	RONDELLE 10,5 X 18 X 1,6
16	0335043	SECHSKANTMUTTER	HEXAGON NUT	ECROU A SIX PANS

16.01 EINBAUWASSERENTHÄRTER

16.01 INCORPORATED SOFTENER

16.01 ADOUCISSEUR INCORPORE



Ew16_1a.doc
01.06.98/FUS

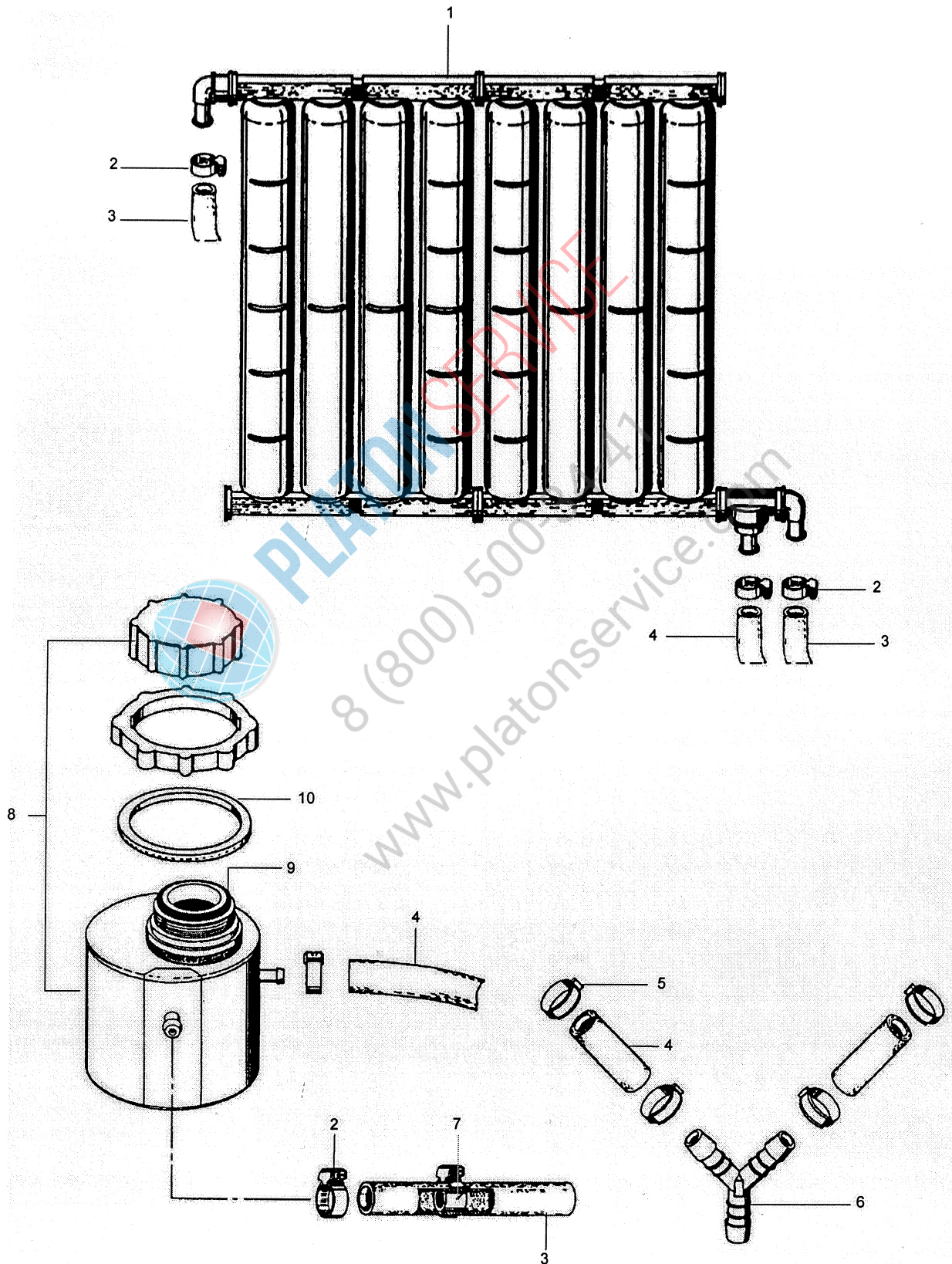

16.01 EINBAUWASSERENTHÄRTER

16.01 INCORPORATED SOFTENER

16.01 ADOUCISSEUR INCORPORE



Ew16_1a.doc
01.06.98/FUS

POS	IDENT. NR. IDENT. NO.	BEZEICHNUNG	DESIGNATION	DESIGNATION
1	0270065	BASENAUSTAUSCHER EW 5, 8 ZYLINDER, FV/OR	SOFTENER EW 5, 8 CYLINDERS, FV/OR	ADOUCISSEUR EW 5, 8 CYLINDRES, FV/OR
	8002734	BASENAUSTAUSCHER EW 5, 8 ZYLINDER, DV	SOFTENER EW 5, 8 CYLINDERS, DV	ADOUCISSEUR EW 5, 8 CYLINDRES, DV
	8002210	BASENAUSTAUSCHER EW 2,5, 4 ZYLINDER, FV25/30/FR30	SOFTENER EW 2,5, 4 CYLINDERS, FV25/30/FR30	ADOUCISSEUR EW 2,5, 4 CYLINDRES, FV25/30/FR30
2	0233037	SCHLAUCHKLEMME 16 - 27	HOSE CLAMP 16 - 27	PINCE/TUYAUX SOUPLES 16-27
3	0640012	SCHLAUCH GRAU, 1/2"	HOSE GREY, 1/2"	TUYAU FLEXIBLE GRIS, 1/2"
4	0640030	SCHLAUCH GRAU, 3/8"	HOSE GREY, 3/8"	TUYAU FLEXIBLE GRIS, 3/8"
5	0233077	1-OHR-KLEMME	1-EAR CLAMP	BORNE A UNE OREILLE
6	0621040	Y-STÜCK YS 10	Y-PIECE YS 10	PIECE DE -Y- YS 10
7	8004068	MENGENREGLER KPL.	FLOW CONTROL DEVICE COMPL.	REGULATEUR DE VOLUME COMPL.
8	* 0270106	SALZLÖSEBEHÄLTER	SALT DISSOLVING CONTAINER	RESERVOIR-DISSOLUTION DU SEL
9	* 0270107	O-RING 39 X 4	O-RING 39 X 4	BAGUE O 39 X 4
10	9500825	FLACHDICHTUNG	FLAT PACKING	GARNITURE PLATE
	0270104	FÜHRUNGSRING	GUIDING RING	BAGUE DE GUIDAGE
	8005092	VERDREHSICHERUNG	TWIST PROTECTION	PROTECTION DE TORSION



PLATON SERVICE
8 (800) 500-24-47

www.platonservice.com

17.05 REINIGERDOSIERUNG
17.05 DETERGENT DOSING UNIT
17.05 DOSEUR DE DETERGENT

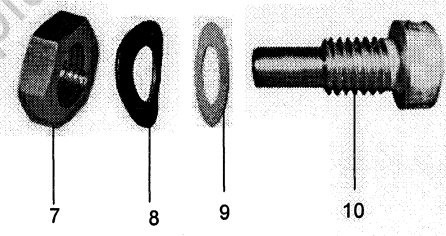
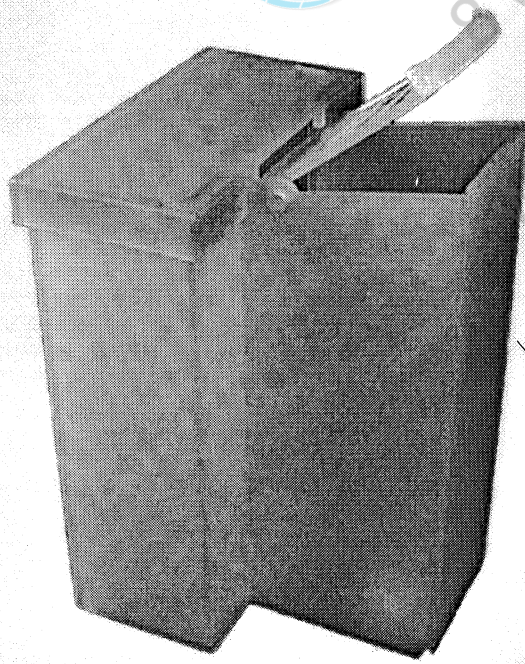
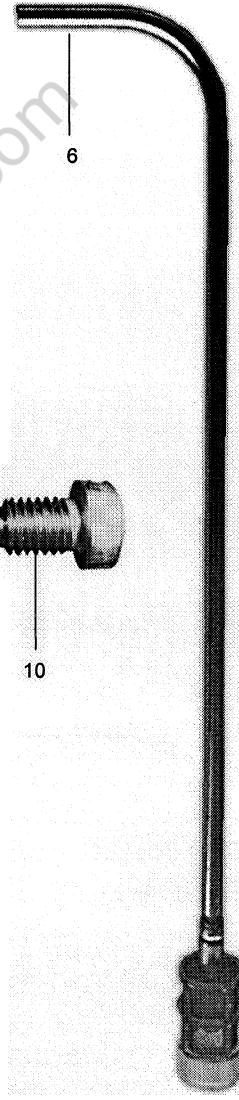
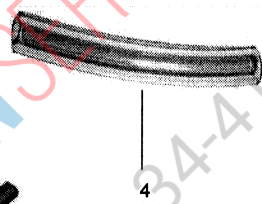
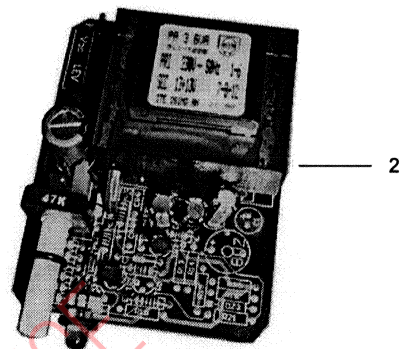
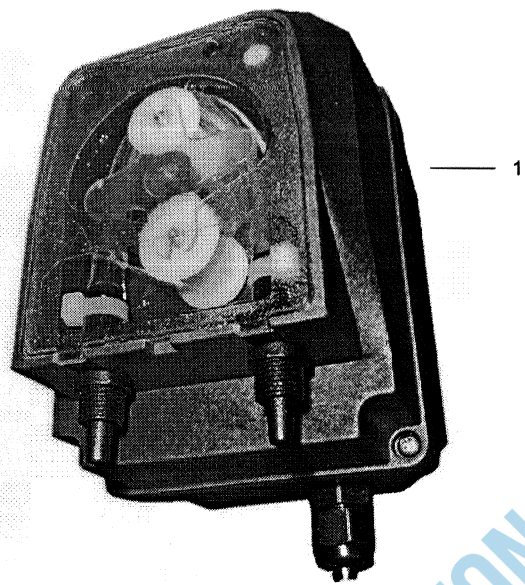

17.05 REINIGERDOSIERUNG

17.05 DETERGENT DOSING UNIT

17.05 DOSEUR DE DETERGENT



Rd17_5a.doc
01.12.2000/FH

POS	IDENT. NR. IDENT. NO.	BEZEICHNUNG	DESIGNATION	DESIGNATION
1	* 9511667	REINIGERDOSIERGERÄT PR7, 230V 50HZ	DETERGENT DOSING UNIT PR7, 230V 50HZ	DOSEUR DE DETERGENT PR7, 230V 50HZ
2	9505653	DREHZAHLREGELUNG	SPEED CONTROL	REGULATEUR DE VITESSE
3	* 9511675	DOSIERSCHLAUCH 7 L/H SANTOPRENE	DOSING HOSE 7 L/H SANTOPRENE	TUYAU POUR DOSEUR 7 L/H SANTOPRENE
4	* 0260007	SCHLAUCH KLARSICHT 6 X 1,5	HOSE TRANSPARENT 6 X 1,5	TUYAU TRANSPARENT 6 X 1,5
5	* 9500045	DRAHTSCHLAUCHKLEMME 8,8 - 9,3 MM	HOSE WIRE CLAMP 8,8 - 9,3 MM	COLLIER DE SERRAGE 8,8 - 9,3 MM
6	8005393	ANSAUGROHR, 340 MM	SUCTION TUBE, 340 MM	CONDUITE D'ASPIRATION 340 MM
6	8005372	ANSAUGROHR, 420 MM	SUCTION TUBE, 420 MM	CONDUITE D'ASPIRATION 420 MM
7	0335019	SECHSKANTMUTTER DIN 934 - M10	HEXAGON NUT DIN 934 - M10	ECROU A SIX PANS DIN 934 - M10
8	9603790	FEDERSCHEIBE M10	SPRING WASHERV M10	RONDELLE ÉLASTIQUE M10
9	* 9603787	FLACHDICHTUNG 10X16X2	FLAT PACKING 10X16X2	GARNITURE PLATE 10X16X2
10	8000013	SCHLAUCHANSCHLUß	HOSE CONNECTION	CONNEXION DE TUYAU FLEXIBLE
11	8004424	REINIGERBEHÄLTER K 376	DETERGENT CONTAINER K 376	CONTENEUR DE DETERG. K 376
12	0113098	MAGNETVENTILFILTERSIEB	FILTER FOR SOLENOID VALVE	TAMIS-FILTRE D'ELECTROVANNE



PLATON SERVICE
8 (800) 500-3424
www.platonservice.com

Das Programm auf einen Blick

1

**Spülautomaten mit stationärem
Waschverfahren**
Geschir- und Gläser-spülautomaten;
Topf- und Behälterspülautomaten;
Salat- und Gemüsewaschautomaten

2

Spülautomaten mit Durchlaufsystem
Geschirrspülautomaten mit Bandtransport-,
Korbtransport- oder Umlaufsystem

3

Spezialspülanlagen
Vollautomatische Spülanlagen für Geschirr,
Tablets und Besteck; Flight-Catering-
Anlagen; Industriespülautomaten; Trolley-,
Behälter- und Transportwagenspülanlagen

4

Förderanlagen
Tablet- und Geschirrttransportbänder,
Geschirrsortier- und Stapleinrichtungen

5

Speisereste-Behandlungsanlagen
Maschinen und Anlagen zur Aufbereitung
von Speiseresten für eine umweltgerechte
Entsorgung

6

Großkücheneinrichtungen
Geräte und Mobiliar für Relais- und Stations-
küchen; Transportwagen; Tablet- und Teller-
stapler; Tische, Schränke und Regale aus
Edelstahl; diverse Organisationsmittel

7

**Sanitäreinrichtungen für Krankenhäuser
und Heime**
Reinigungs- und Desinfektionsautomaten
für Steckbecken und andere Pflegegeschirre;
Pflegekombinationen; Komplettausstattung
für Unreine Arbeitsräume

Our product range

**Automatic dishwashing machines
with fixed washing system**

**Belt conveyor and rack transport
machines**
for continuous throughput operations

Special purpose warewashing solutions
such as semi and fully automatic systems,
designed for the catering industry in general

Conveying systems
for vertical and horizontal transport of trays
and dishes

Food waste treatment systems
Water conditioning appliances

Central wash-up equipment
Tables, cabinets, tray and plate stackers

**Sanitary appliances for healthcare
establishments**
Automatic cleaning and disinfection
appliances for bedpans and other care
utensils

Notre gamme de production

**Lave-vaisselle à procéder de lavage
stationnaire**
Automates de lavage

**Lave-vaisselle automatiques à passage
continu**
Lave-vaisselle automatiques à convoyeur et
à transport de paniers

Lave-vaisselle spéciaux
Installations de lavage entièrement
automatiques et semi-automatiques,
lave-vaisselle industriels

Installations de transport
pour le transport vertical et horizontal de
plateaux

**Installations de traitement de déchets
alimentaires**
ainsi que des installations de traitement
d'eau

Installations pour grandes cuisines
Tables, empileurs de plateaux et d'assiettes

**Installations sanitaires pour hôpitaux et
maisons de soins**
Automates de nettoyage et de désinfection,
combinés de soins



MEIKO Maschinenbau GmbH & Co. KG
Englerstr. 3 · 77652 Offenburg · Germany
Tel. + 49 (0)781/203-0
Fax +49 (0)781/203-1274
e-mail: info@meiko.de · www.meiko.de